

Automation in dry ice production Conveyor System

The challenge

To move from manual to automated production – that was the dream of a dry ice manufacturer. Here, the challenge was to overcome the different ejection and working heights of the various machines, as well as to fulfill the need for a mobile solution. When the belt conveyors are not in use, it must be possible to push them aside. Another challenge: Production wanted to be able to saw up blocks of ice.

The solution

With a total of five belt conveyors – two TB40s and three TB30s – we automated the dry ice production as the customer requested. Because the TB30 belt conveyor after the dry ice block machine has an incline, a second belt conveyor or a conveyor with a bend is not necessary. The belt saw that saws the ice blocks up is placed between the two TB30 belt conveyors positioned next to one another. And so that mobility is guaranteed, all five belt conveyors

Der Nutzen

- Optimized, resource-sparing work process
- Simple solution for balancing out height differences
- Easy access to the processing machine thanks to a mobile base
- Use only when needed
- Flexible use for different processing machines
- Attractive, functional design
- Slim, space-saving solution thanks to inclined belt conveyors

Technical Data

Belt type	TB30-105/K, TB30-250/K, TB40-400
Drive	Brushless DC motor
Max. transport weight	25 kg, 25 kg, 30 kg
Speed	1.0 – 51.5 m/min, 1.0 – 33.5 m/min
Incline	14 % and 45 %

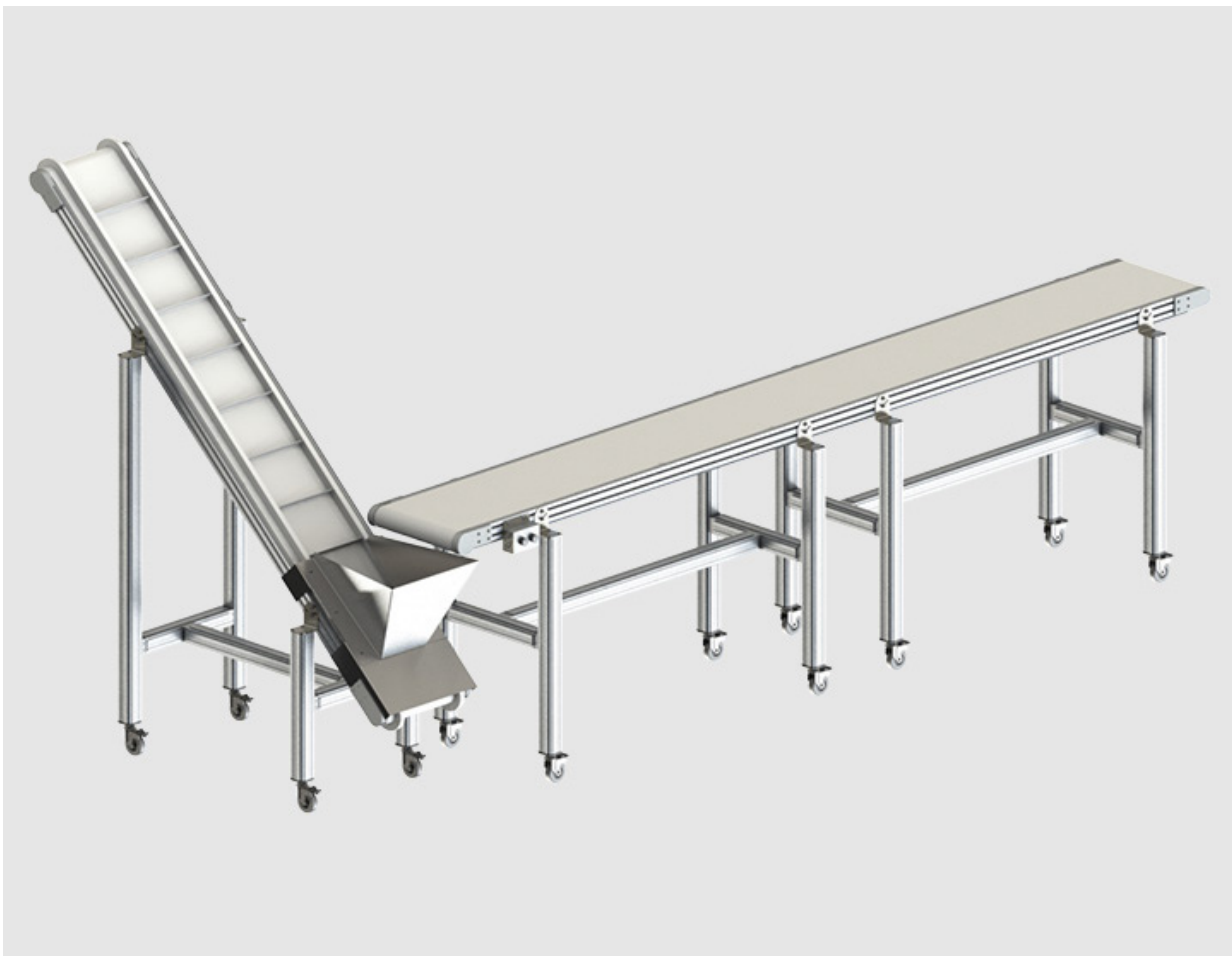

Headquarters

Montech AG
Gewerbstrasse 12
4552 Derendingen, Switzerland
+41 32 681 55 00
www.montech.com
sales@montech.com

USA Branch

Montech Conveyors Corporation
3425 Asbury Avenue
Charlotte, NC 28206
(980) 207-3622
www.montech.com/us/en
info.us@montech.com