

SOLTB-V VACUUM CONVEYOR

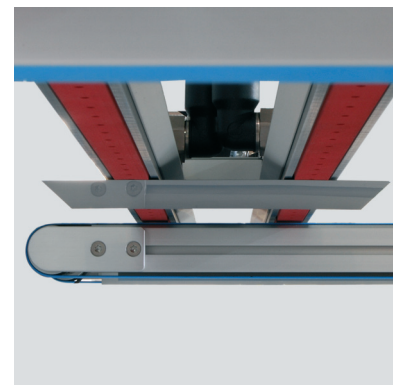
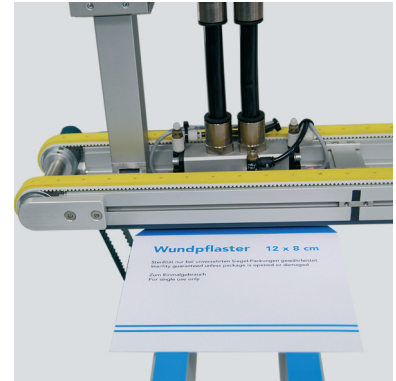
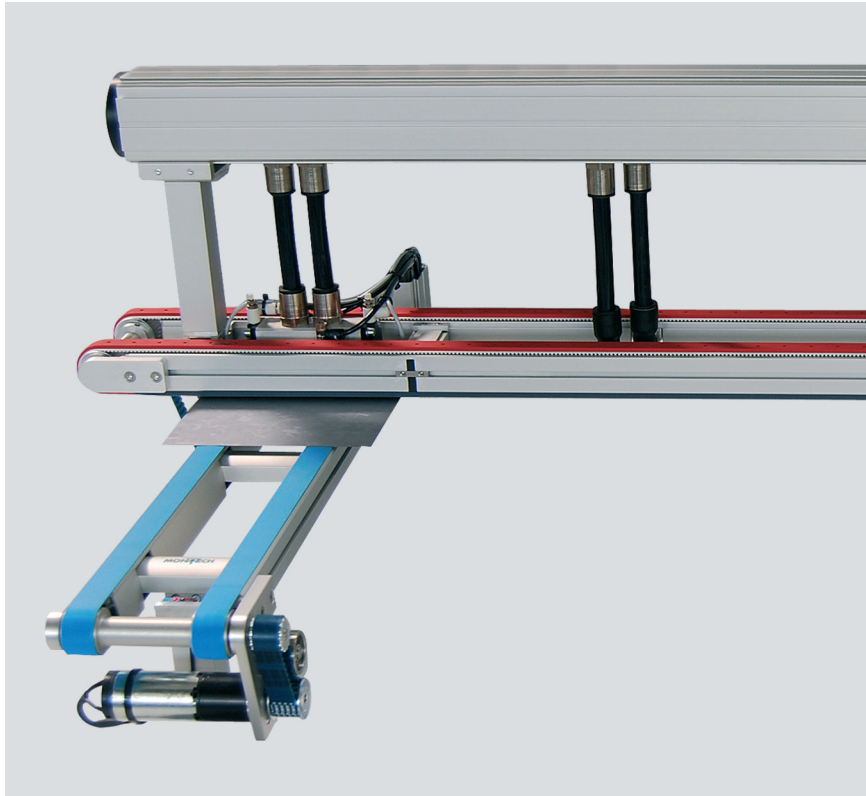

Montech's vacuum conveyors transport large quantities of flat, delicate or lightweight workpieces or solar wafers at speeds up to 5 m / 16 ft per second. Montech's vacuum conveyors can be customized to meet your needs, including overhead transportation, and feature compact dimensions. Conventional handling and transport solutions require an unproductive return track. Montech's vacuum conveyor has no return track, which helps increase productivity, and is extremely cost effective compared to other systems.

VERSIONS:

- Vacuum conveyor with belts
- Vacuum conveyor with toothed belts
- Vacuum conveyor with toothed belts for overhead transportation

ADVANTAGES:

- > *Overhead transportation possible*
- > *Large quantities of workpieces or solar wafers can be handled simultaneously*
- > *No nonproductive return track*
- > *Compact dimensions*

VACUUM CONVEYOR SOLTB-V - DIMENSION

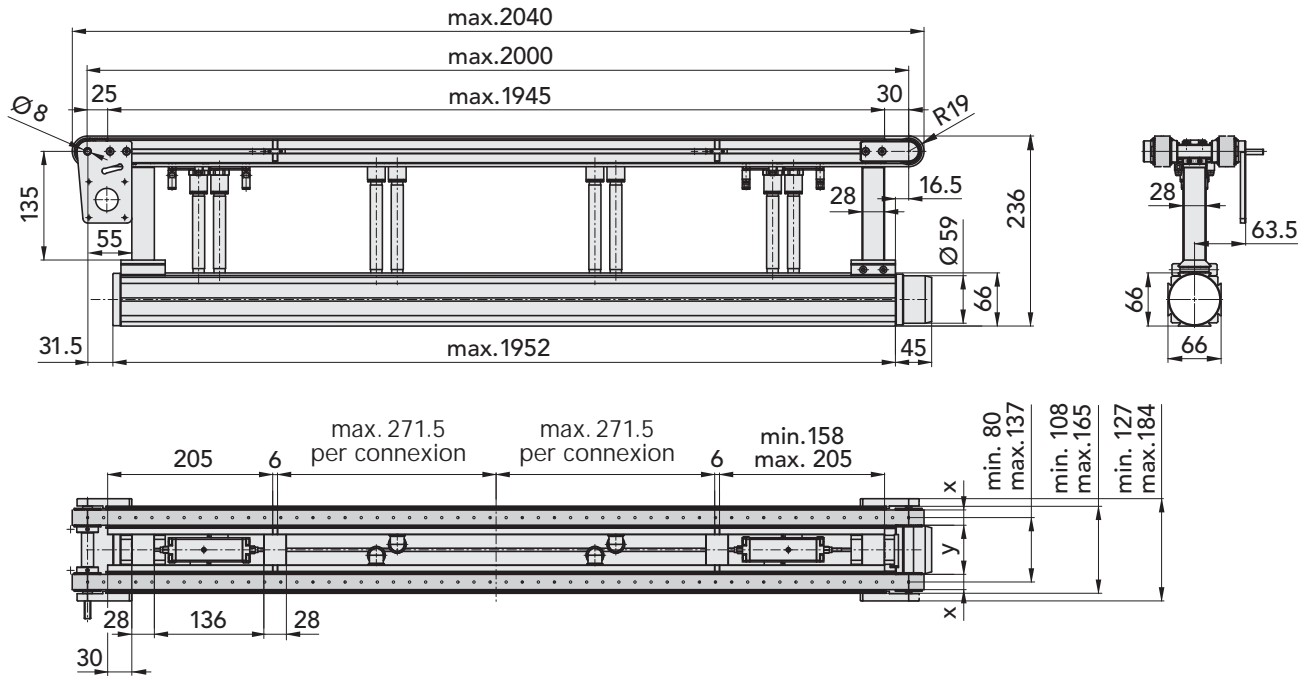

Versions	x	y
with belts	20	min. 60 / max. 117
with toothed belts	19	min. 61 / max. 118
with toothed belts for overhead transportation	14	min. 66 / max. 123

VACUUM CONVEYOR SOLTB-V TECHNICAL - DATA

Chassis width	[mm]	108 (standard – width over 108 mm on request)
Conveyor length	[mm]	2000 (middle roll – roll)
Required drive torque	[Nm]	min 1.5
Belt speed	[m/s]	max. 5
Acceleration and brake ramp	[m/s ²]	max. 20
Ambient conditions: temperature	[°C]	10–40
rel. humidity		<95% (without condensation)
air purity		normal workshop atmosphere



Montech Conveyors Corp.
 13420 Reese Blvd. West
 Huntersville, NC 28078
 Phone 704-659-2186
 info.us@montech.com
 www.montech.com