



Custom Solutions with Montech's Belt Conveyors, Transfer Systems

Smart, efficient and space saving

## The Challenge

Space at the installation site is limited, and the main process line for workpiece processing is occupied with bulky positioning and straightening units. The empty workpiece carrier cannot be retracted as usual in parallel at the same level due to space limitations. Moreover the workpieces to be processed must be protected against electrostatic discharge (ESD).

## The Solution

A smart and innovative lift connection for return of the workpieces can be a space-saving and elegant solution.

In the Montech pallet-handling system LT40, the completely processed products are carried on an ESD-compliant workpiece carrier by the pneumatically driven lift solution autonomously in a continuous process back to the main line for further processing.

## Benefit

- Efficient, autonomous continuous processings
- Easy, direct access to production cells
- High flexibility and variability in the main assembly line and manufacturing line
- Independent process expansion
- Optimal use of production area
- Attractive and functional design

## Specifications

System	Pallet-handling system LT40
Pneumatic pressure lift	5 – 6 bar
Maximum speed	59.05 ft/min
Return line at working height	78.74" – +/-0.78"
Main line at working height	37.40" – +/-0.78"
Framing system	Aluminium framing system Quick-Set, size 40

## Application impressions

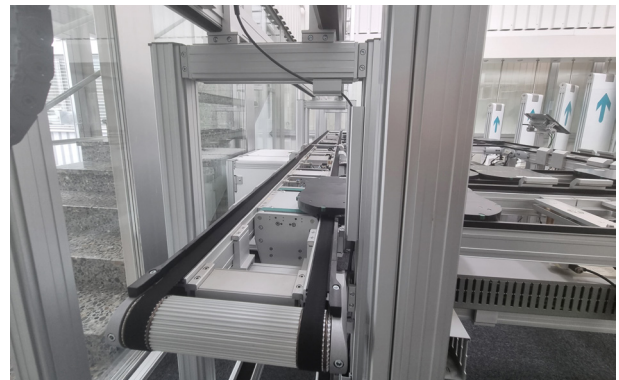
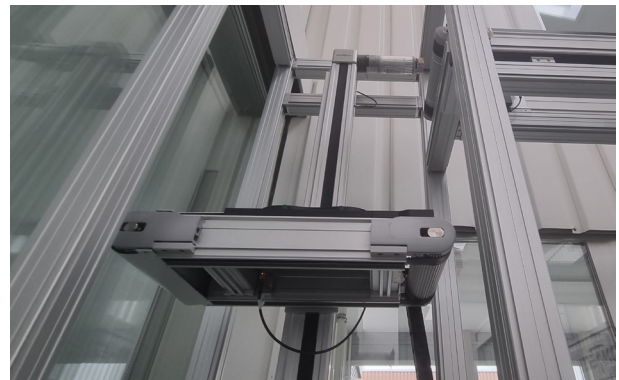
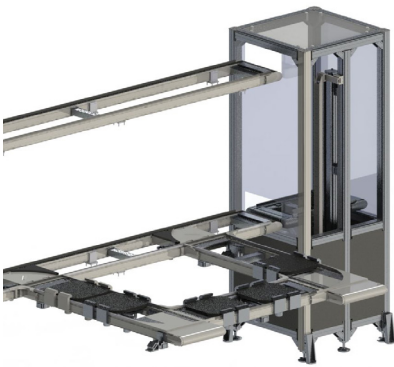

Headquarter:  
Branch USA:

Montech AG, [sales@montech.com](mailto:sales@montech.com)  
Montech Conveyors Corp., [info.us@montech.com](mailto:info.us@montech.com)